

THIS DRAWING IS UNPUBLISHED. RELEASED FOR PUBLICATION
 © COPYRIGHT BY TYCO ELECTRONICS CORPORATION. ALL RIGHTS RESERVED.

LOC	DIST	REVISIONS					
AF	50	P	LTR	DESCRIPTION	DATE	DWN	APVD
			C1	REVISED PER ECR-07-030301	09MAY08	HMR	JR

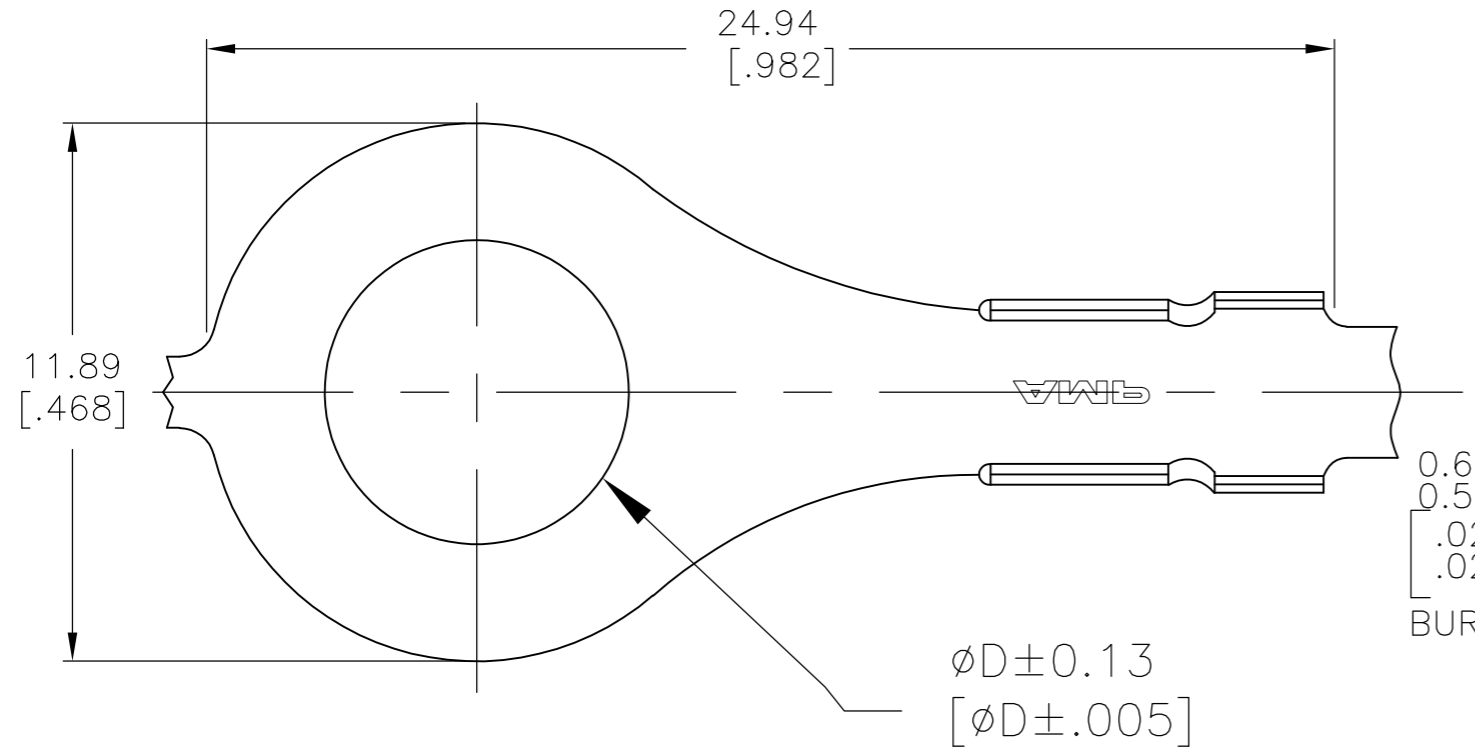

1 CONTINUOUS STRIP ON REELS

FORMED IN APPLICATOR 60700-1-S ONLY

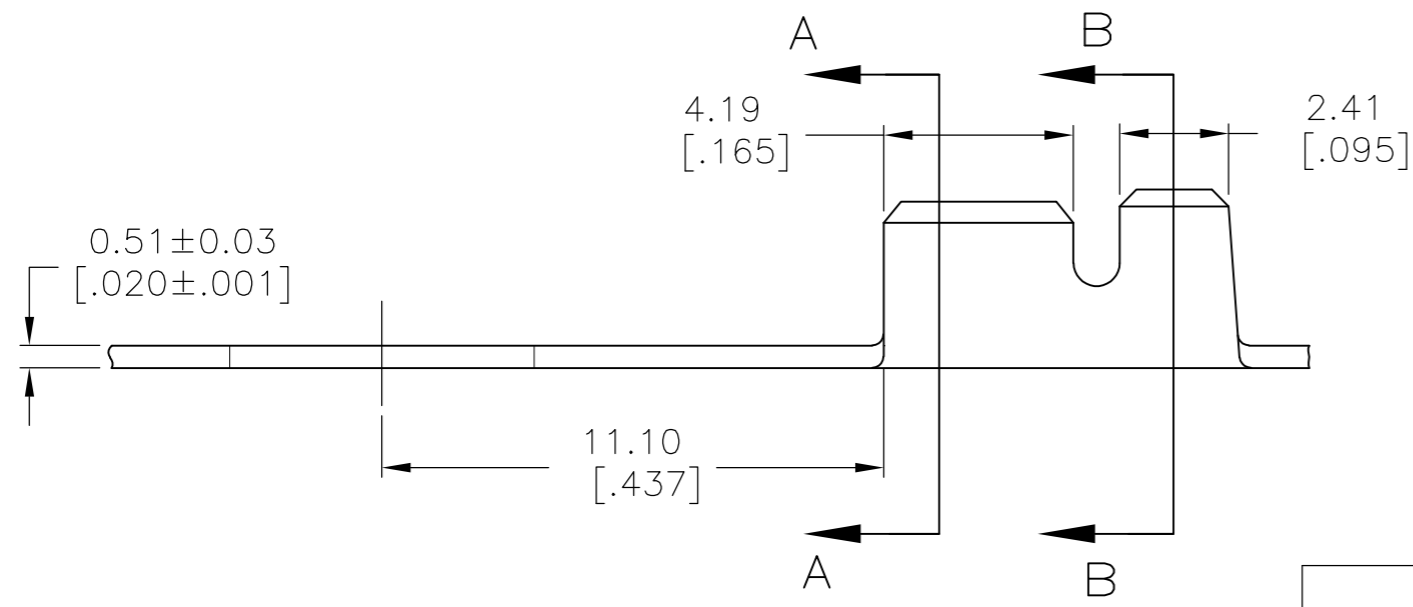
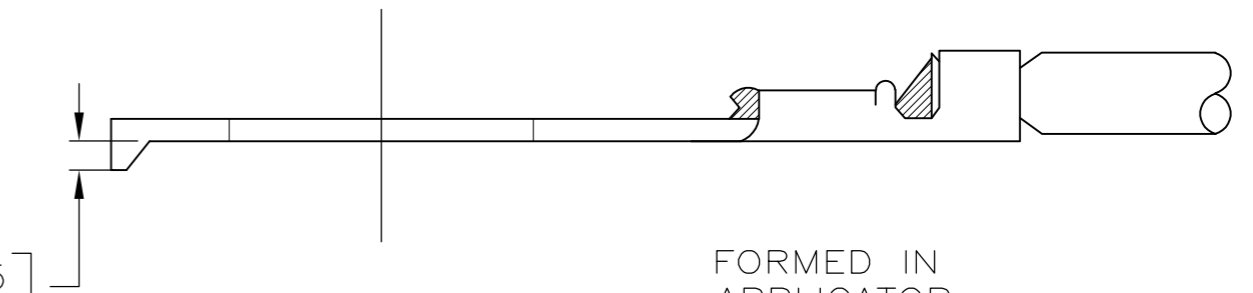

SECTION A-A

SECTION B-B

	6.73 [.265]	M6 1/4	0.5-1.4 mm ² [20-16]	2.03-3.05 [.080-.120] DIA	NONE TIN TIN	BRASS STEEL	60700-3 60700-2 60700-1
OBSOLETE	8.76 [.345]	---					
	DIM 'D'	STUD SIZE	WIRE RANGE	INSULATION RANGE	FINISH	MATERIAL	PART NO.

THIS DRAWING IS A CONTROLLED DOCUMENT.

DIMENSIONS: mm [INCHES]	TOLERANCES UNLESS OTHERWISE SPECIFIED:	DWN RAGHAVENDRA 09MAY08	Tyco Electronics Corporation Harrisburg, PA 17105-3608
	0 PLC ± - 1 PLC ± - 2 PLC ± 0.38 [.015] 3 PLC ± - 4 PLC ± - ANGLES ± 1' 0'	CHK JEFF RUTH 09MAY08 APVD JEFF RUTH 09MAY08 PRODUCT SPEC - APPLICATION SPEC - WEIGHT -	
MATERIAL SEE TABLE	FINISH SEE TABLE	RESTRICTED TO -	

CUSTOMER DRAWING SCALE 6:1 SHEET 1 OF 1 REV C1